

ABSTRACT:

A pusher canard aircraft convertible for road use where the canard outer sections are removable and are stored within the aircraft fuselage and the outer main wing sections rotate horizontally for storage on the fuselage top. The fuselage is designed as a lifting body which gives the aircraft three lifting surfaces. The lifting body takes advantage of 'ground effect, resulting in a lower landing speed. In road mode the vehicle as a 2 or 4 passenger model is smaller than a full size automobile. Hydraulic motor wheels propel the aircraft/vehicle for road use. An internal combustion engine within the fuselage drives the propeller for air operation. The propeller is disengaged, not removed, for land operation and the engine is used to drive an hydraulic pump to power the motor wheels for road use. A single nose wheel or two front wheels are used for both steering in landing/taxiing and for road use. In road mode, the appearance is as much like a van than as an aircraft. In flying mode, the appearance is not to unconventional.

BACKGROUND- DESCRIPTION OF PRIOR ART

For the past nine decades, almost since the Wright brothers first flight, men have dreamed of a vehicle that could be driven on land and also be flown. There have been successful flights of such vehicles and some were even certified for flight, but none have proven practical as these vehicles had to shed their flying components (wings, tail structures and sometimes their fuselage sections and propellers in order to function as a land vehicle. The additional weight penalty of carrying an auto part, even a special light weight auto part, required a very large flying structure and a much larger engine than required for regular aircraft with similar load carrying capacity and speed. None of these "flying cars" had the important advantages of the 'roadable aircraft of this invention where all flying components remain attached to or within the roadable aircraft for land operation.

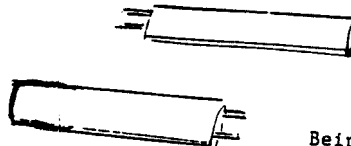
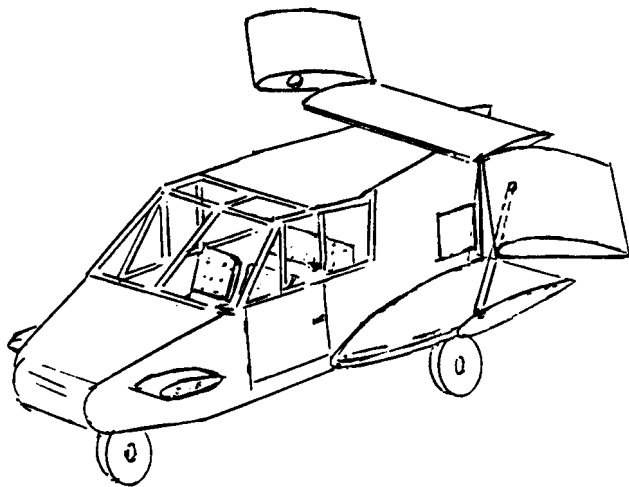

Air-Van
Being converted for
Road Use or Flight

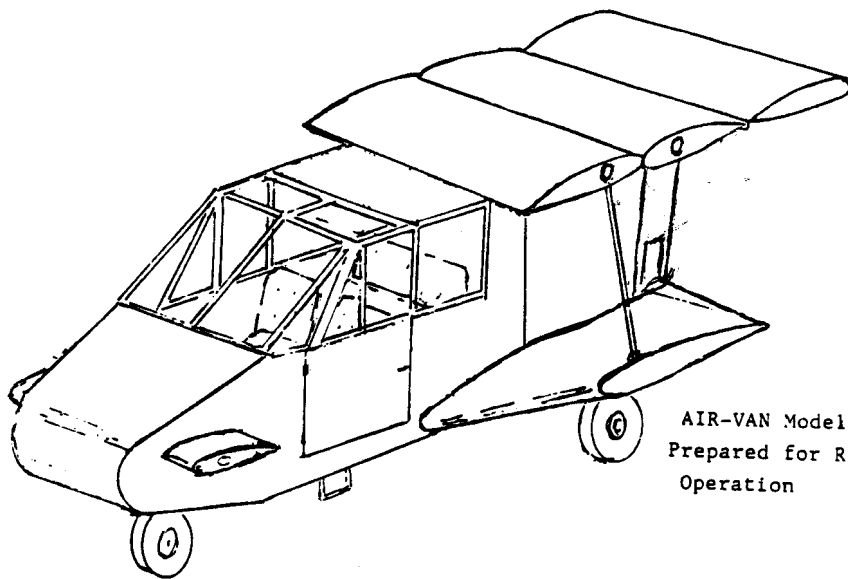

AIR-VAN Model 4
Prepared for Road
Operation

Patent Pending

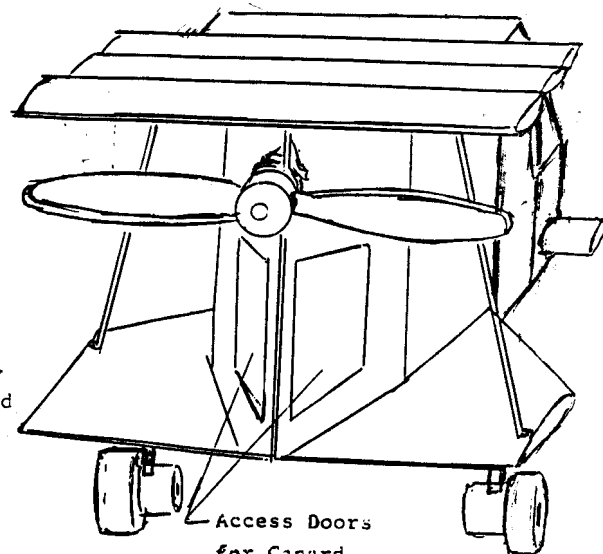

Air-Van
In Road Mode

Access Doors
for Canard
Storage

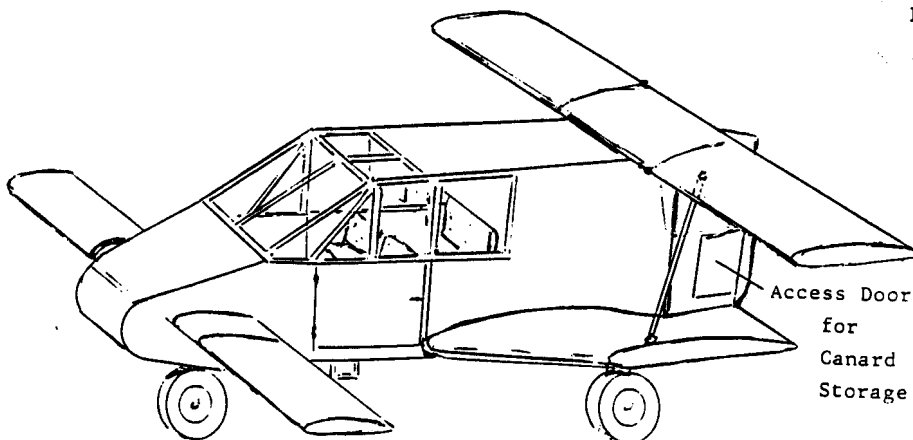

AIR-VAN Model 4
Prepared for Flight

Access Door
for
Canard
Storage

www.air-van.com

Air-van
Currently seeking financing for
final design, construction and
flight testing of a prototype

Harry Einstein
98 Parkwood Drive
kingston, RI 02881

(401)792-9139
einst-res@home.com

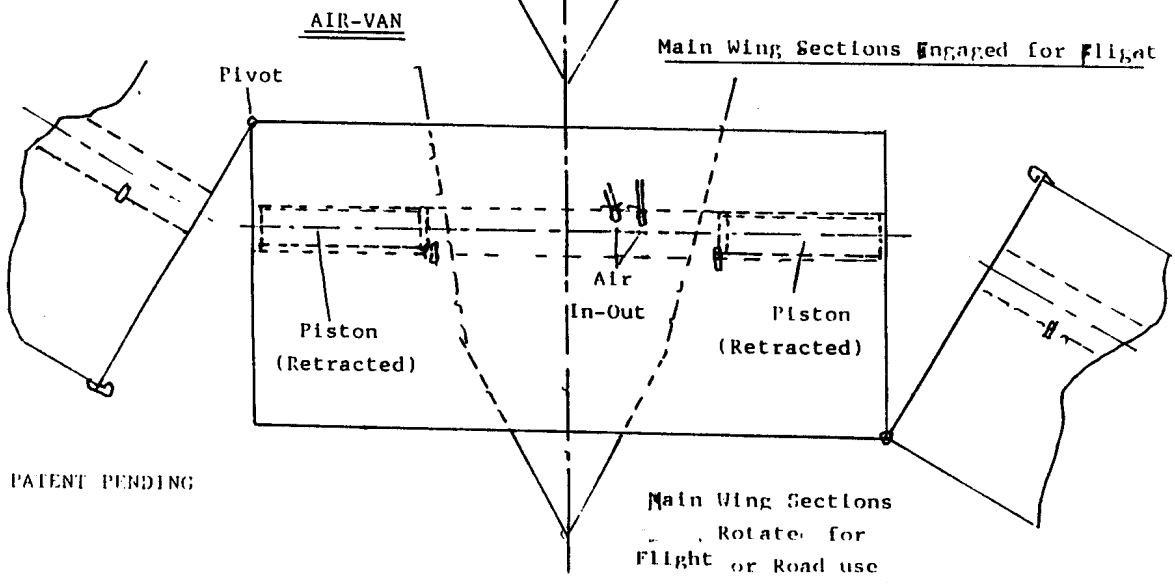
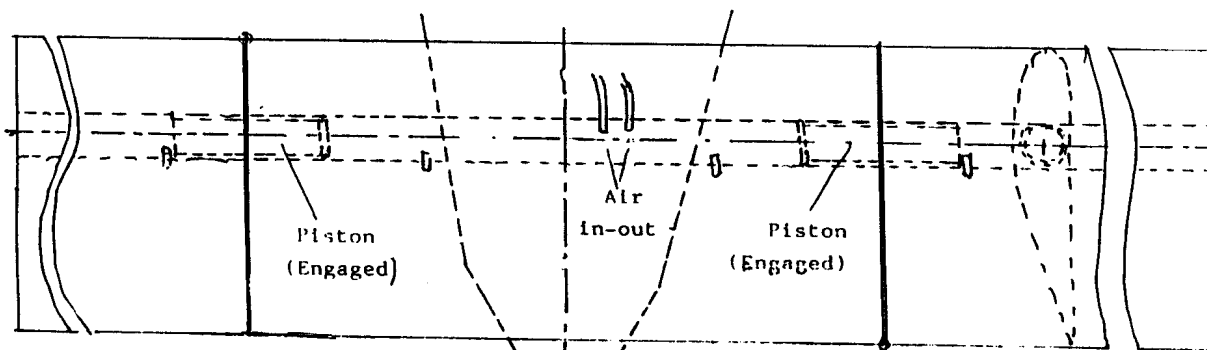

PATENT PENDING

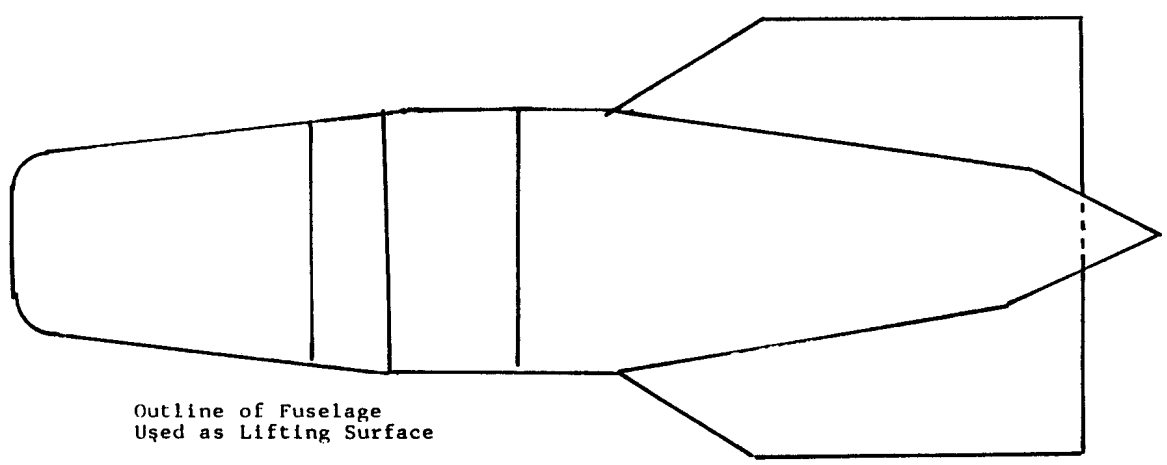

AIR VAN Patent Pending

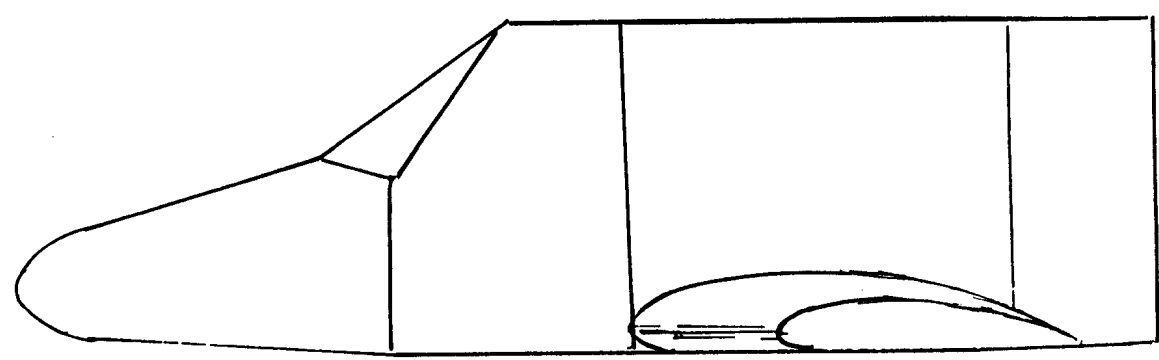

H. Einstein